

## **FROM AIR SPARGED HYDROCYCLONE TO GAS ENERGY MIXING (GEM) FLOTATION**

<sup>1</sup>Miroslav Colic, <sup>1</sup>Dwain E. Morse, <sup>1</sup>Wade O. Morse, <sup>1</sup>Thomas G. Matherly  
<sup>1</sup>CWT; R&D Division; 6860 Cortona Dr., Building A, Goleta, CA 93117.

Presenting Author: Dr. Miroslav Colic

### **ABSTRACT**

Flotation is solid/liquid separation technique designed to remove all particles - generally encountered as very fine emulsions, suspended solids and colloids from wastewater. The Air - Sparged Hydrocyclone (ASH) was designed to enhance collisions of mineral particles with sparged gas bubbles and on this basis specific capacities of as much as 100 times those of traditional flotation equipment were achieved. We will describe modifications of the ASH, which have enabled us to apply it in wastewater treatment processes. The modified and improved version of ASH is called Bubble Accelerated Flotation (BAF). This system has achieved exceptional removal of contaminants from industrial wastewater and process water, while requiring smaller footprints with lower operating cost. In addition to the air - sparged BAF we have developed an induced air BAF, a vacuum flotation BAF, and an electro - flotation BAF. Design modifications that resolve the operational problems of traditional ASH are discussed. In the most recent development benefits of centrifugal hydrocyclone mixing were combined with ultrasmall dissolved air flotation bubbles. This led to the development of the unique hybrid dissolved air - centrifugal flotation, which we termed Gas Energy Management Mixing (GEM) flotation. Real world examples of industrial wastewater treatment with the BAF and GEM systems will also be discussed, along with fundamental science needed to design the process. Commercial applications of the systems include treatment of petroleum, heavy metal laden, laundry, screen-printing, food and beverage processing and animal livestock wastewaters.

**Keywords:** wastewater treatment, bubble accelerated flotation, centrifugal-dissolved air flotation, dual polymer flocculation, liquid cyclone mixing

### **INTRODUCTION**

Froth flotation and other processes in the mineral industry are designed to maximize separation of one particle type from another or improve mineral concentration. On the other hand, flotation processes in water and wastewater treatment are designed to remove all suspended particles, colloids, emulsions and even some ions or soluble organics that can be precipitated or adsorbed on suspended solids (phosphate, sulfide, heavy metals). In this case, the process is optimized by the maximum recovery of cleaned water with the lowest concentration of contaminants. It is also often desired that the recovered sludge contain high percentage of solids. Such solids can sometimes be recycled and reused. The design features and operating conditions of flotation equipment used for this purpose must be modified accordingly. It is evident that the processes causing water loss to the

froth phase or migration of solids to the water phase must be minimized and appropriate conditions established for complete particle recovery.

It is particularly common to encounter wastewater that contains a mixture of suspended particles and stable oil emulsions. It is well known that it is difficult to remove oily contaminants from wastewater and other natural and industrial systems containing oil. Oil can be present as a non-dispersed surface layer, usually floating at the air/water interface. Such layers can easily be removed. On the other hand, if oil is present as a dispersed phase in the form of fine droplets (oil in water emulsions) separation is much more difficult. Many emulsions are stabilized with surfactants or other emulsifying agents. Modern emulsions often contain droplets, which are very small (size range of less than 10 microns) and stabilized with powerful emulsifying agents. De-emulsification and oil extraction from such systems present particular challenges. Moreover, such processes have to be economically feasible to be accepted by industry.

Sedimentation is one of the favorite gravity separation methods to remove contaminants in water treatment. Most oils have low density and cannot be separated by sedimentation from water streams. On the other hand, flotation is much more suitable technique to remove oil from water during or after de-emulsification. Flotation is a process in which one or more specific particulate constituents of a slurry or suspension of finely dispersed particles or droplets become attached to gas bubbles so that they can be separated from water or other constituents. Gas/particle aggregates float to the top of the flotation vessel where they are separated from water and other non-floatable constituents.

One of the key steps in the flotation methods is the introduction of air bubbles into water. In the early flotation devices coarse bubbles (2 to 5 mm) were introduced into the liquid to be treated by blowing air through canvas or other porous material. In some impeller based machines air could be introduced from the atmosphere without compressors or blowers. This type of flotation in which impeller action is used to provide bubbles is known as induced air flotation (IAF) and also produces fairly coarse bubbles. Such flotation methods are not suitable for wastewater treatment and oil extraction. Jameson recently developed an (Clayton et al, 1991) improved version of induced air flotation, which was more successful in the removal of fats oil and grease from the wastewater. Another flotation method, the so-called dissolved air flotation (DAF) is much more common in the treatment of oily wastewater. In DAF, a stream of wastewater is saturated with air at elevated pressures up to 5 atm (40-70 psig). Small bubbles are formed and continuously flowing particles are brought into contact with bubbles. There is a price to pay for having such small bubbles (up to 20 microns): such bubbles rise very slowly to the surface of the tank. This is main driver of the large dimensions of DAF tanks. Final solubility of gas in water, even at high pressures, also results in fairly low air to water ratios. Air to water ratios of 0.15 : 1 are common in DAF systems and it is very difficult to achieve higher ratios.

One of the recent developments in flotation technology circumvented some of these problems. In particular, the air-sparged hydrocyclone (ASH) (Miller, 1981) couples a porous cylindrical membrane to the liquid-liquid hydrocyclone. Gas is introduced through the porous membrane while wastewater is pumped through the hydrocyclone. Such a device is not dependent on the gas solubility and can introduce air to water ratios

as high as 100: 1. Because the bubbles are sheared off the wall of the porous membrane due to centrifugal forces inside the hydrocyclone, they are broken up into very small sizes compared to those observed in the DAF. Thus, even though ASH is essentially a mechanically sparged device similar to the IAF or early flotation devices, it does not suffer from similar problems.

Because the ASH is essentially a modified hydrocyclone device, it has similar restrictions. Removed particulates in such devices are forced through an overflow device known as vortex finder. In the ASH, the creation of an overflow results in a separate stream of contaminated water with a low concentration of solids. This deficiency results in sludge with low particulate concentrations and a larger volume of waste.

Here we discuss modifications to the ASH device. The bubble accelerated flotation (BAF) evolved from ASH technology to address operational limitations resulting from the traditional stream - splitting approach of hydrocyclones. The BAF no longer incorporates a cleaned - water underflow restriction that forces the froth and contaminants to be ejected through an overflow device, known as vortex finder. Removing the underflow restriction in the BAF improves the operational consistency and ease. At the point at which the stream exits the BAF hydrocyclone, the bubble - particle aggregates have already formed, and coagulation and flocculation are complete before the froth particles are ejected with the cleaned water through the underflow. The requirement to separate this froth in the receiving tank from the treated water results in the new system described below.

### **BUBBLE ACCELERATED FLOTATION SYSTEM (BAF)**

The BAF system consists of a bubble chamber (BC) and a BAF tank. The BC can be operated with sparged air, induced air, vacuum, electro - flotation and even dissolved air. We will first describe the air sparged BC and BAF system. Such systems are commercially installed and successfully operated in over twenty locations within the US. Figure 1 contains an illustration of the air - sparged BC. Wastewater is introduced through a liquid - liquid hydrocyclone head (tangential injection) at the top of the unit. The tangential inlet creates a swirl flow and causes centrifugal acceleration as the water is forced into a swirl layer against the inner wall of an inert porous tube. A gas plenum, which encloses the porous tube, is pressurized commonly with low pressure air from a blower. The air pressure must slightly exceed the water pressure due to the centrifugal acceleration and the resistance of the tube itself. Gas forced through the tube generates bubbles on the inside surface that are extremely buoyant in the centrifugal field because of the effective radial pressure gradient in the swirl layer generated by the hydrocyclone action. The bubbles accelerate toward the inner surface of the swirl layer. In addition to creating the radial acceleration of the bubbles, the centrifugal field also aids in the classification of particles with densities different from that of water. The acceleration across the swirl layer usually ranges from 25 to 1000 G's during routine operation. Even though the residence time of the liquid stream in the BC is only a fraction of a second, due to their rapid acceleration the bubbles traverse the short distance across the swirl layer (typically 1 cm for a 15 cm diameter unit) in milliseconds. During this time, the bubbles collide

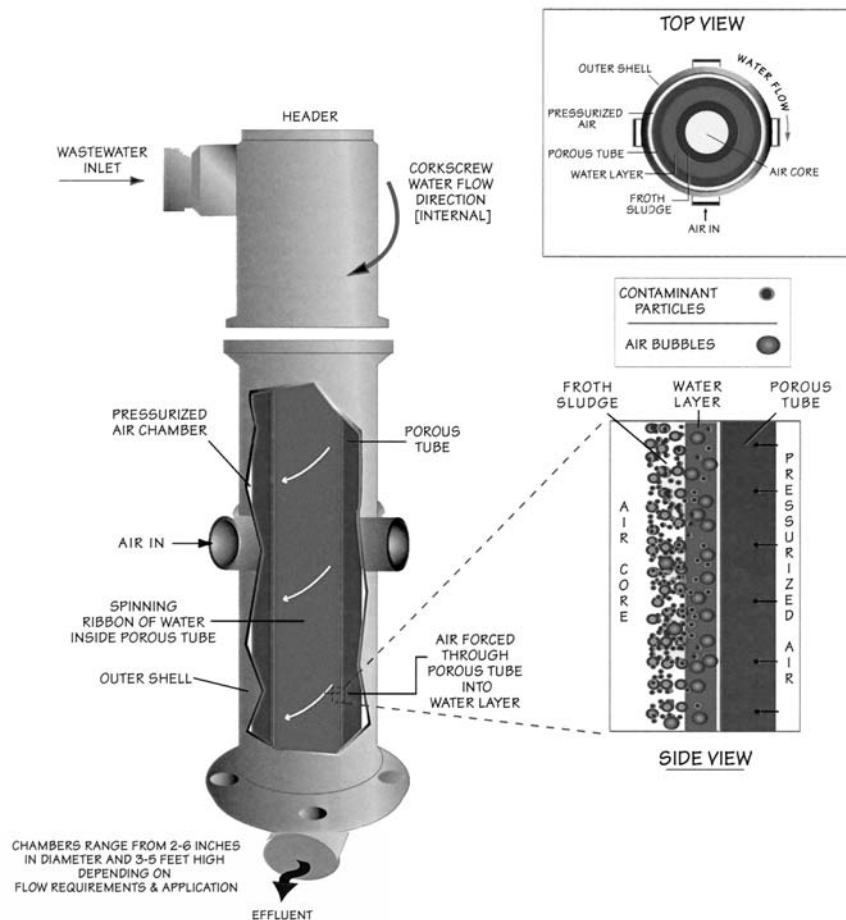

FIGURE 1. A cut-away view of a bubble chamber.

with particles moving toward the porous tube and form bubble - particle aggregates. Another advantage of the sparging gas is that it cleans and protects the porous tube from scaling and fouling.

Given the small bubble size, large bubble flux and the kinetic paths of the bubbles through the swirl layer, gas - transfer rates are very high. This results in the ability to remove volatile organic species or to aerate the water if desired.

The flotation process is completed outside the BC in the BAF tank. In a DAF system, the *tank* is designed to allow sufficient residence time for the bubbles and particles to collide, and for the resulting aggregates to rise to the surface. This results in a requirement of low hydraulic flow rates in order to permit bubble - particle aggregates to form and to float to the surface without being swept out of the system. In DAF systems, the low hydraulic flow rate is accomplished by increasing the cross - sectional area of the flow and consequently enlarging the tanks. Consequently, for the DAF there is a trade - off between footprint and residence time.

The design needs for BAF separation tanks are completely different. The BC has already created bubble-particle-polymer aggregates before they enter the tank. The tank is simply used as a separator and not to achieve bubble-particle contact. Unlike in other flotation tanks, the effluent from the BC can enter the tank above the water level, resulting in a shorter distance for the froth to reach the surface. This feature, combined with the fact that the aggregates are already formed, permits much higher hydraulic flow rates through the flotation tank. Figure 2 illustrates the BAF tank with the BC attached. The detailed description of the tank design can be found in Morse et al., 2001, Colic et al, 2001 , Owen et al, 1999.

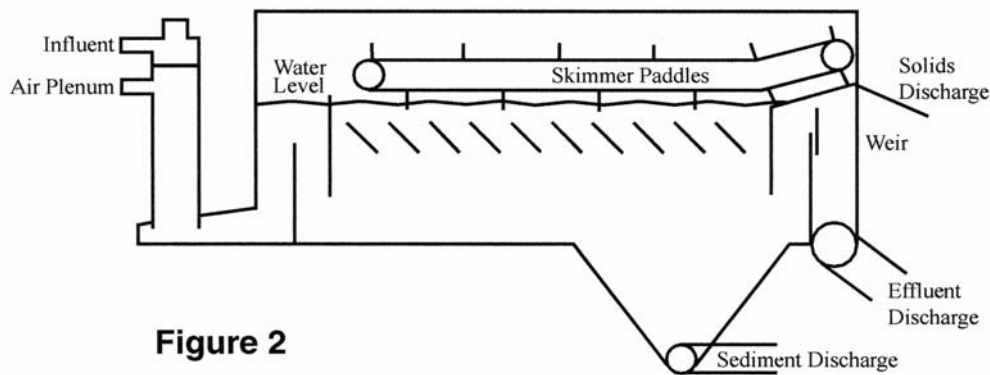

FIGURE 2. A cut-away view of a Bubble Accelerated Flotation Tank (B.A.F.).

**Figure 3**

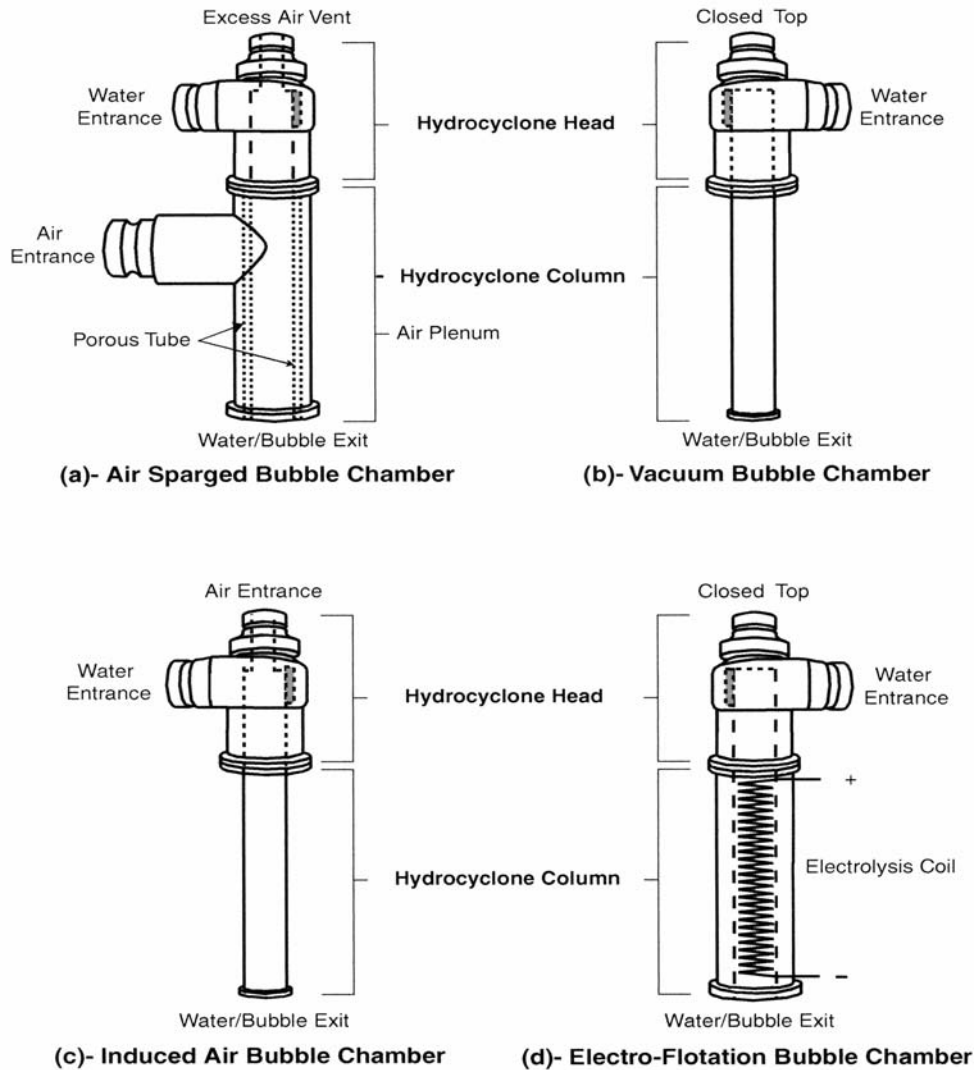

FIGURE 3. A cut-away view of (a)-Air Sparged Bubble Chamber, (b.)-Vacuum Bubble Chamber, (c.)- Induced Air Bubble Chamber and (d.)- Electro-Flotation Bubble Chamber.

In addition to the air - sparged BC, we recently developed an induced air BC, vacuum flotation BC and electro - flotation BC. In the induced air BC, the top of BC is open and in contact with the air, as shown in Figure 3c. This configuration enables the vortex turbulence formed inside the BC to be used to mix in air from the environment. This obviates the need for expensive air blowers and sparge tubes, which get fouled. If the top of the BC tube is closed, the vortex inside the tube creates a vacuum that helps nucleate

air bubbles of very small size. Such a system is shown in Figure 3b. Finally, if a helical coil made from conductive material such as platinized titanium or stainless steel is placed inside the tube of the BC, electric current can be used to electrolyze wastewater and produce fine hydrogen and oxygen bubbles. If chloride is present in the water, some chlorine can also be released, which helps in disinfection. An electro - flotation BAF is shown in Figure 3d. Currently we are developing a dissolved air BAF system, which shows even better separation efficiencies with much less air and lower pressures than in the DAF.

## **APPLICATION OF BAF SYSTEMS and LIQUID CYCLONE MIXING IN WASTEWATER TREATMENT**

Examples of installations and performance data for the air - sparged BAF are outlined in Table 1. There are currently more than twenty systems installed within the continental US. The advantages of the system are small footprint, high performance, high solids loading in the sludge and low amount of treatment chemicals used. The technology is particularly efficient in the removal of free and emulsified fats, oils and grease (FOG). Following successful flocculation, the BAF system can also be used to remove low density submicron particles such as latex particles used in screen - printing of fabrics. The BAF system has also been used to remove totally hydrophilic particles such as zeolites or quartz. The BAF system has a much shorter response time to changes in chemistry used (seconds as opposed to hours in clarifiers or DAF). This is very useful in wastewater treatment as incoming water often changes, unlike the streams in mineral flotation.

Numerous approaches were used to coagulate and flocculate particulates in wastewater prior to the BAF treatment. The pH of the suspension is usually adjusted close to the pH of the isoelectric point. The residual charge is then partially neutralized with either inorganic coagulants or low molecular weight cationic polymers (polyamines, polyDADMAC's etc.). Dual polymer flocculation with high molecular weight (HMW) cationic and anionic polyacrylamide flocculants (PAM's) was then performed. Dual polymer flocculation with HMW PAM's yielded large, stable flocs which float very efficiently inside the BAF tank. We also observed that if the main portion of the charge is neutralized with low molecular weight cationic coagulants, the BAF performance was not as good. Among the most efficient polymeric flocculants used were Cytec's C-498 HMW cationic polyacrylamide with ultra high molecular weight (> 10,000,000 D) and 0.55 charge density and Cytec's anionic polyacrylamide A-130 HMW with molecular weight estimated to be over 70,000,000 D. When animal feed applications of the collected sludge are desired, Cytec's "GRAS" (generally regarded as safe) polymers such as 234 GDH cationic moderate molecular weight polyacrylamide are used. When necessary, emulsion polymers were also used with BAF system. Dual polymer flocculation also results in very low residual polymer concentration in the effluent. This is particularly important, when flotation is used as a pretreatment ahead of membrane separation processes. Membranes are particularly sensitive to fouling with cationic polymers.

## BAF™ Performance Classified by Industry

<b>Meat &amp; Seafood Processors</b>										
Location	Process	BOD Before (mg/l)	BOD After (mg/l)	BOD % Removal	TSS Before (mg/l)	TSS After (mg/l)	TSS % Removal	FOG Before (mg/l)	FOG After (mg/l)	FOG % Removal
Los Angeles, CA	Seafood	3190	1308	59	1675	67	96	n/a	n/a	n/a
Westport, WA	Seafood	1375	564	59	484	189	61	166	25	85
Salinas, CA	Renderer	1000	300	70	800	80	90	300	30	90
Denver, CO	Renderer	n/a	n/a	n/a	600	60	90	560	28	95
Klingerston, PA	Egg Product	656	210	68	391	133	66	n/a	n/a	n/a
West Liberty, IA	Turkey	600	210	65	532	133	75	n/a	n/a	n/a
Kent, WA	Meat	1882	320	83	1120	56	95	1100	22	98

<b>Food Processors</b>										
Location	Process	BOD Before (mg/l)	BOD After (mg/l)	BOD % Removal	TSS Before (mg/l)	TSS After (mg/l)	TSS % Removal	FOG Before (mg/l)	FOG After (mg/l)	FOG % Removal
Los Angeles, CA	Mayonnaise & Salad Dressing	11925	954	92	7500	75	99	n/a	n/a	n/a
Tennessee	Salad Dressing & Vegetables	12083	2900	76	3000	150	95	n/a	n/a	n/a
Madera, CA	Olive Processor	2200	1100	50	1000	50	95	316	95	70
Modesto, CA	Corn & Potato	335	672	77	250	50	98	n/a	n/a	n/a
Denver, CO	Corn & Potato	2958	710	76	1960	98	95	n/a	n/a	n/a
Umatilla, OR	Onions	1099	747	32	540	54	90	n/a	n/a	n/a
Hilmar, CA	Dairy	2900	1450	50	1500	75	95	266	80	70

<b>Laundry &amp; Wash Facilities</b>										
Location	Process	BOD Before (mg/l)	BOD After (mg/l)	BOD % Removal	TSS Before (mg/l)	TSS After (mg/l)	TSS % Removal	FOG Before (mg/l)	FOG After (mg/l)	FOG % Removal
Los Angeles, CA	Pre-Wash & Dye	489	318	35	416	50	88	n/a	n/a	n/a
Fresno, CA	Wash-Rack	n/a	n/a	n/a	n/a	n/a	n/a	400	20	95
Lexington, KY	Laundry	347	250	28	450	45	90	n/a	n/a	n/a

**Table 1- Examples of full-scale operating installations of BAF flotation systems.**

It was also observed that high molecular weight polymeric flocculants can be added directly into the BC head. Large size batch mixing tanks or floc tubes can therefore be avoided. Powerful vortex mixing and wall effects inside the BC tube result in better uncoiling of polymers with minimum polymer and floc breakage. HMW flocculants can therefore achieve superb flocculation inside BC. This often results in the formation of large flocs with diameters of up to 10 cm. The flocs are very stable, with high solids loading of between 10-30% upon short drainage. The best flocs are usually produced when using a combination of HMW cationic and anionic flocculants. Somasundaran and coworkers (1999) showed that dual polymer flocculation actually results in more efficient uncoiling of the HMW polymeric flocculants. The uncoiled flocculant chains then act as better bridging agents. Vortex mixing inside the centrifugal field within the BC seems to enhance this process. Additional research should be performed to investigate these processes.

## **TOTAL FLOTATION SYTEM**

Flotation systems need several other supporting components for their optimal operation (Ross et al., 2000).

1. Screening. Proper screening of large solids (e.g. product solids, trash, soil) from an industrial wastewater stream reduces the solids loading, chemical consumption downstream and maintenance requirements due to clogged valves, orifices, pumps and piping. Screening is one of the most often overlooked parts of the total system. Savings by cutting the screen from the system design can later result in a significant increase in the cost of treatment.
2. Equalization Tanks (EQ). Proper equalization of an industrial effluent can provide a more constant and homogeneous flow to the flotation unit. This can improve the effectiveness of the chemical treatment program used for coagulation and flocculation prior to flotation. In addition equalization reduces hydraulic surging, which can be detrimental to the system performance. In some cases EQ tanks can be sized to allow operation of the flotation units during specific time periods (e.g., a single plant shift), thus reducing operator labor costs.
3. Chemical addition. Most chemical addition systems utilize either flocculation (floc) tubes or flash/floc tanks to introduce chemicals into process flow. Recently designed hybrid centrifugal – dissolved air systems add coagulants or flocculants directly into the flotation chamber – bubble nucleation unit. The coagulants and flocculants must be prediluted with water in chemical mixing tanks with proper mixdown systems. Enough time must be allowed to hydrate – activate polymers after dilution with water or to dissolve granular flocculants. The coagulation and flocculation systems must be designed to provide a proper amount of mixing energy and time for the adequate mixing of chemicals with wastewater constituents but without break-up of formed flocs. Prior to coagulation and flocculation precise pH control can significantly improve system performance and help save on dosage of coagulants and flocculants. The pH can be adjusted in EQ tanks, with fine tuning inside floc tubes or flash mixing tanks or inside the centrifugal chamber of centrifugal flotation units.

4. Floc/sludge handling. Modern flotation technologies can produce sludge with solids loadings over 10%. Collecting, transferring and pumping such sludge is a challenge. Proper selection of transfer pumps, storage/draining tanks and dewatering systems can significantly lower the total cost of wastewater treatment. Polymers that are nontoxic are available. This enables reuse of sludge in some situations such as animal feeding operations.

5. ~~\_\_\_\_\_~~Sensors and automatic control systems. Most users prefer systems that are virtually fully automated. This is only possible with application of high quality sensors that monitor system performance and adjust variables as needed. For instance systems that monitor the pH and adjust it by controlling acid or base dosing pumps are quite reliable. It is still difficult to find reliable systems for adjusting dosage of coagulants and flocculants, as wastewater changes with time.

**Figure 4 - Schematic Presentation of the Total Flotation System (Adapted from Ross et al., 2000)**

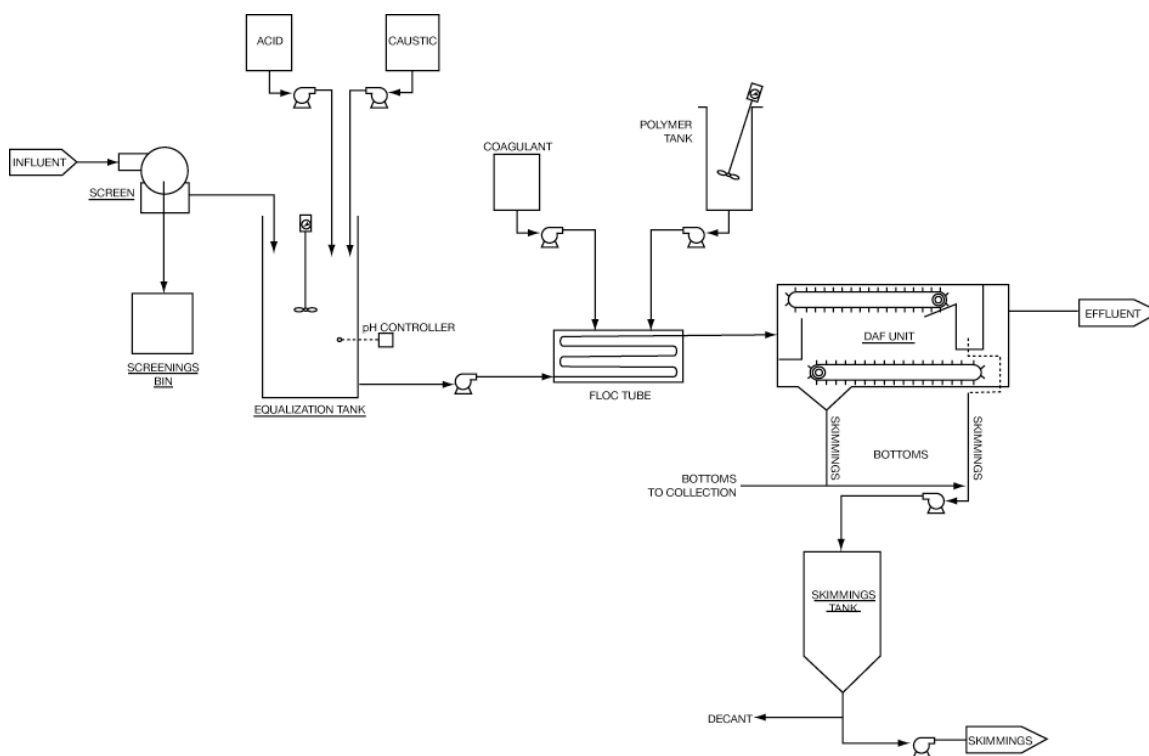

# THE HYBRID CENTRIFUGAL – DISSOLVED AIR FLOTATION SYSTEM: GAS ENERGY MIXING MANAGEMENT FLOTATION (GEM)

Description and Principles of Operation

**Figure 5 – Schematic Presentation of the LCPP/LSGM**

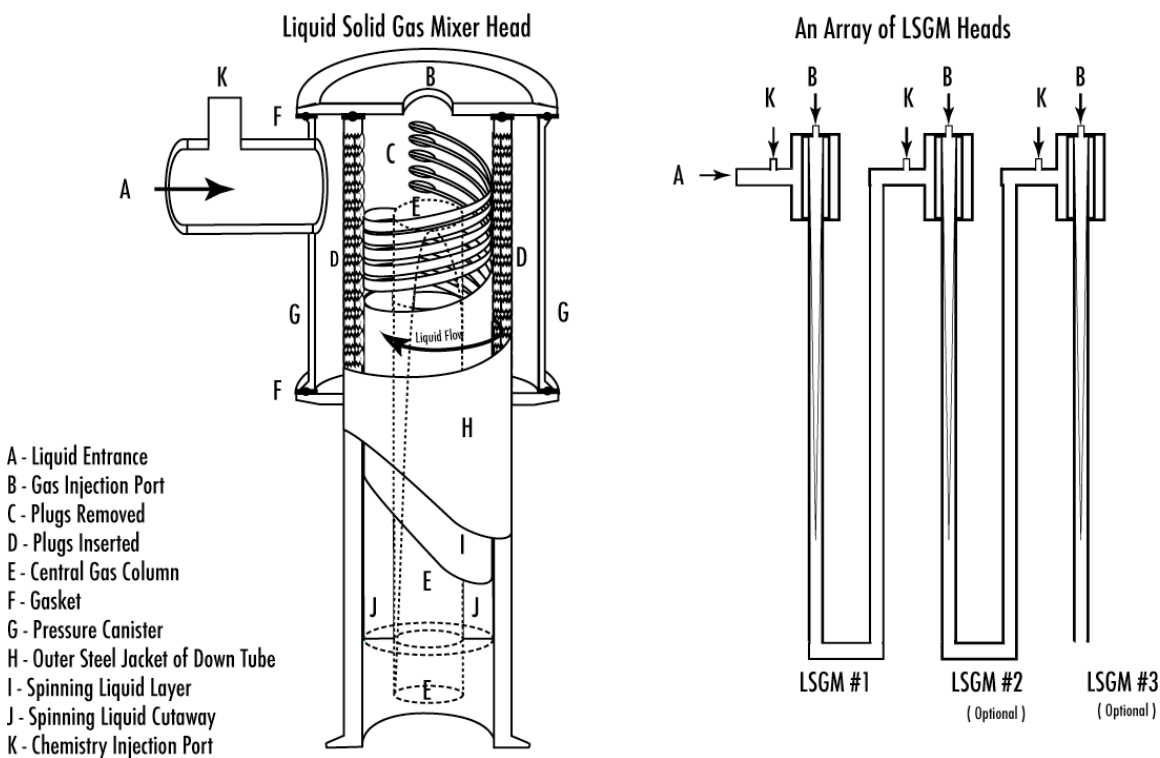

As mentioned in the introduction, in dissolved-air flotation, bubbles are formed by a reduction in pressure of water pre-saturated with air at pressures higher than atmospheric and up to 120 psi. The supersaturated water is forced through needle valves or special orifices, and clouds of bubbles 20 to 100 microns in diameter are produced. Yet, to avoid clogging of such orifices with particles, only 20% of already cleaned water is pressurized and recycled to the wastewater stream. This results in a low-energy mixing of the main wastewater stream and the bubble stream. Treatment chemicals, coagulants and flocculants have to be added in mixing tanks upstream. As already described earlier, floc separation happens in this tank, which requires quiescent conditions and a large footprint.

We proposed that a more efficient flotation system could be developed by combining high-energy centrifugal mixing of a liquid cyclone system (we termed it the liquid cyclone particle positioner, LCPP) with dissolved air as a source of flotation bubbles. As in the case of BAF, coagulants and flocculants can be delivered *in situ* directly into the flotation unit. The bubble chamber was replaced with the LCPP for more efficient mixing of treatment chemicals, which occurs during bubble formation and nucleation. Such a

procedure results in flocs, which are very porous and loaded with entrained and entrapped air.

As shown in Figure 5 the LCPP also acts as a liquid-solid-gas mixer (LSGM). Replacing the classical hydrocyclone head with the LCPP provides extremely energetic mixing by sequentially transporting liquid and entrained particles and gas bubbles throughout a centrifugally rotating liquid layer. Microturbulence in such vortices results in all particles and bubbles down to colloidal and molecular size acting as little mixers. Axial and radial forces inside the LCPP help mix coagulants and flocculants with the particles. Uncoiling of polymer and better mixing of ultrahigh-molecular-weight polymers is achieved in the LCPP. Such efficient mixing is important for proper flocculation of suspended particles.

Further modification of LCPP heads, as opposed to hydrocyclone heads, introduced multiple holes with plugs inside the LSGM heads, as shown in Figure 6. By changing the number of plugs, we can modify the mixing energy and head pressure from very low to very high. In this way, we can mix low-molecular-weight coagulant at relatively high energy and high-molecular-weight flocculants at relatively medium and low mixing energy to promote final large floc formation.

Figure 7 presents a schematic of the GEM flotation system. It should be noted that for the sake of clarity only one LSGM head is presented. If more treatment chemicals are added, the LSGM head can be used to properly mix every additional chemical at its proper mixing energy (one mixing head per addition). Water and gas are introduced into the LSGM on top and pumped through the LCPP chamber. After rapid mixing (seconds), pressure is released with the cavitation plate. Nucleating bubbles and flocs are well mixed. As mentioned before, this results in the formation of large flocs full of entrained and entrapped air. Such flocs are already separated from water inside the LCPP nucleation chamber. As flocs enter the tank, they rise quickly to the top where they are skimmed and sent to solids dewatering devices.

As compared to the ASH and BAF, the GEM system uses less energy, since there is no need for air blowers for air sparging. This also results in less noise. Controlled mixing energy produces stable flocs with much less carryover and higher solids loading. The footprint for this system is still only 10 to 20% of the classical DAF or clarifier devices. A blanket of small bubbles inside the tank acts as a "gas filter," filtering out clean water while preventing the transport of small pinpoint flocs into the clean water stream. Also, when wastewater with surfactants is treated, for some reason no foaming occurs inside the GEM system. Finally, it is possible to install sensors close to the nucleation chamber and observe any disturbance in flocculation performance almost instantaneously. This can be used to install turbidity-driven, chemical-additive dosage-control systems. Such

**Figure 6 – Schematic Presentation of the LSGM Heads**

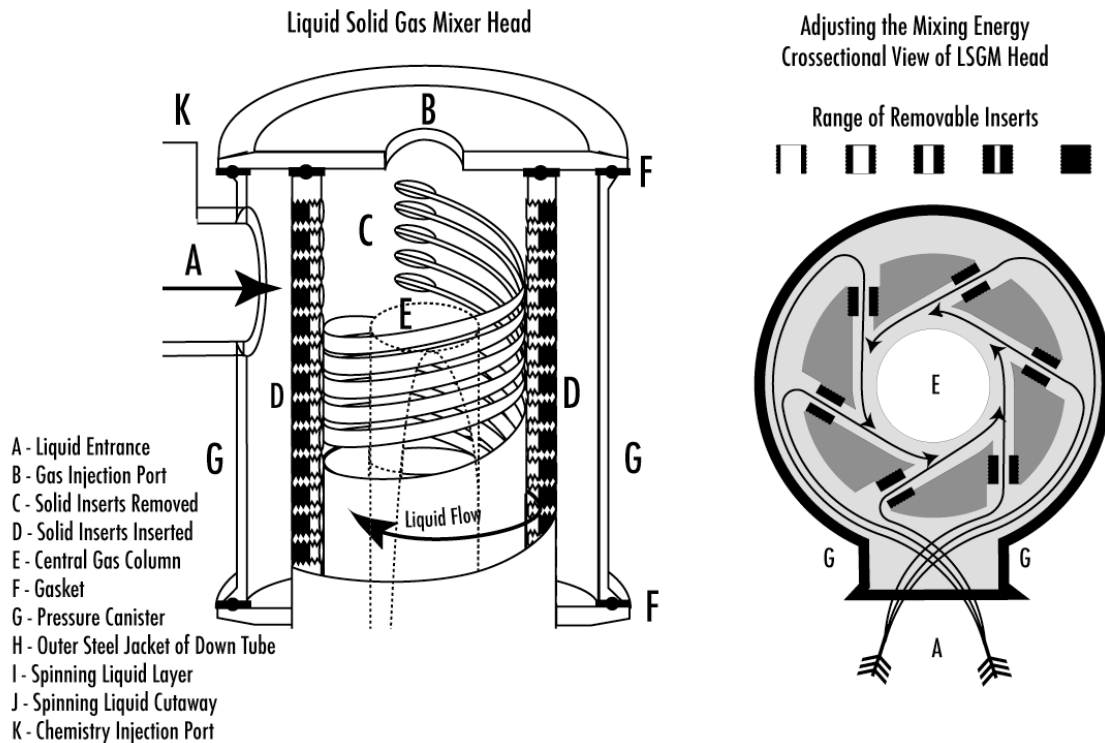

systems can save significant amounts of money and produce a better quality of outgoing wastewater effluent. A detailed description of the GEM system can be found in Morse et al. (2004a, 2004b).

### **OTHER CENTRIFUGAL FLOTATION SYSTEMS**

Swirl flow of fluids and mixing with coagulants, flocculants, and air bubbles occurs inside the air-sparged hydrocyclone (ASH) and other derived centrifugal flotation systems (CFS). Several versions of inverted ASH with upward water flow have been reported. Hydrocyclone flotation systems with induced or dissolved air have also been tested. All these techniques incorporate a vortex finder similar to the classical ASH with

**Figure 7 – Schematic Presentation of the Hybrid Centrifugal – Dissolved Air Flotation System**

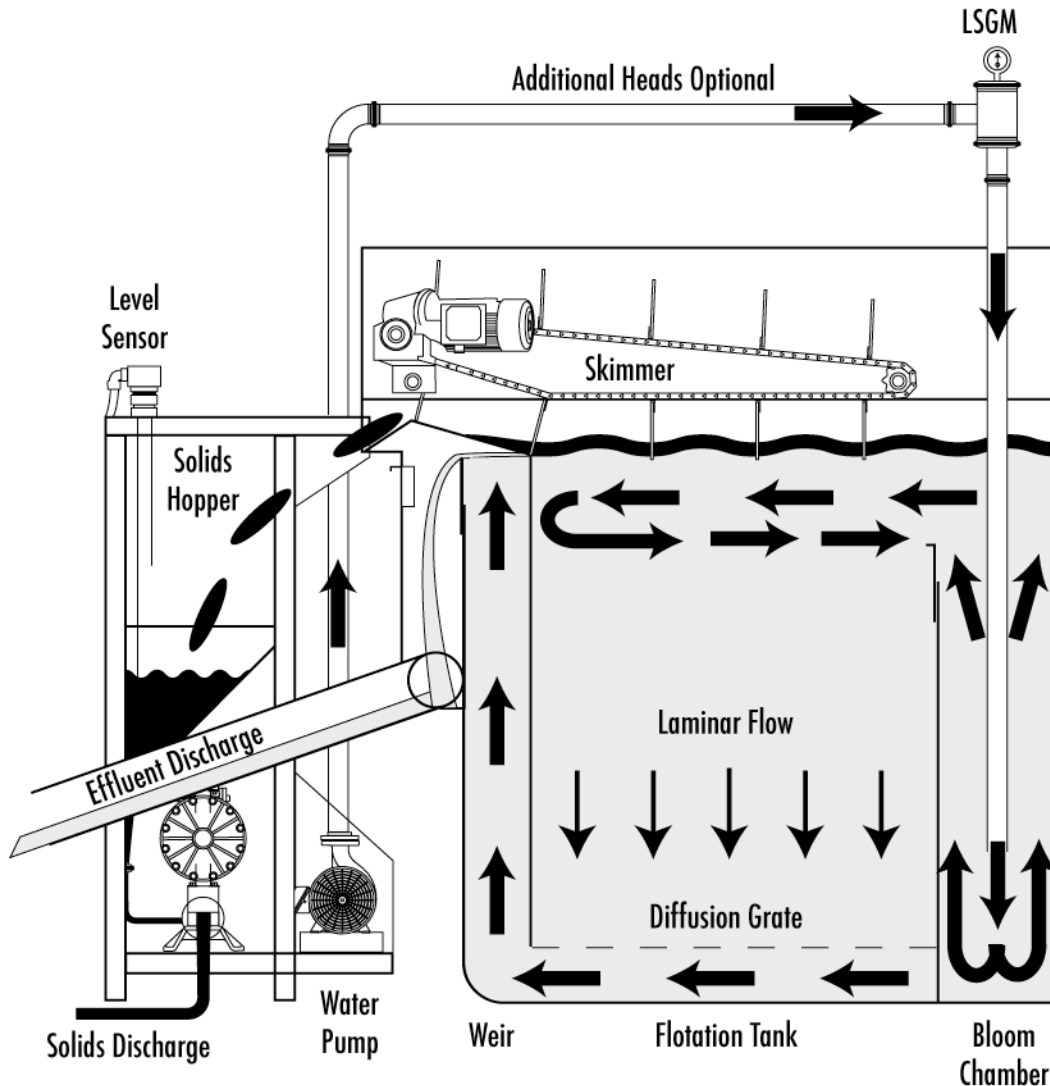

the attendant problems discussed earlier. The advantage of such techniques is that they do not use large separation tanks. This results in a smaller footprint and reduced cost of equipment compared to BAF, DAF, and induced-air flotation.

Modified versions of the jet (Jameson cell) flotation system have also been developed and applied. In a recent advancement of the Jameson cell technology, a new “low shear” method is used to mix the air, untreated wastewater, and flocculants. As in the previously described induced-air BAF system, untreated wastewater and flocculants are gently introduced into the top of the cylinder used for centrifugal mixing (termed the downcomer for Jameson cell systems). A portion of the clean effluent is recycled back into the top of the downcomer. The recycle effluent passes through an orifice,

accelerating the liquid to produce a simple liquid jet. The kinetic energy of the jet results in air being entrained into the downcomer in much the same way as air might be entrained into a bucket of water using a hose. Air is dragged down into the liquid and broken up into small bubbles by the turbulence in the top of the downcomer. The Jameson cell thereby utilizes the energy of the fluid to induce air into the cell, rather than requiring an external compressor or blower. As in the case of the BAF system, the presence of air bubbles at the time of flocculation is extremely beneficial, as it results in the bubbles being entrapped with the actual floc structure. The incorporation of bubbles in the floc structure provides buoyancy and allows particles to be floated independent of their surface characteristics. The downward velocity of the bubble/liquid mixture in the downcomer is designed such that all bubbles have to descend and emerge into a reservoir (or cell) at the bottom of the downcomer. The reservoir acts as a disengagement zone, allowing the aerated floc structures to float to the surface to form a sludge layer. As in the case of BAF and GEM, separation already happens inside the centrifugal force column (in this case downcomer). The sludge overflows the reservoir into a launder, whilst the cleaned effluent passes to the next stage in the process.

Other modifications of jet flotation include the DAF jet (dissolved-air mode) and addition of one more cylinder around the downcomer to lead separated flocs towards the top of the separation tank (Feris et al., 2004). While these modifications increase the cost and result in a more complicated system they also increase the separation efficiency.

Another turbulent *in situ* centrifugal flotation system, termed flocculation flotation (FF), was recently developed (daRosa and Rubio, 2005). As in the case of GEM, BAF, and the modified jet-flotation cell, polymer and air are added at the same time inside a centrifugal mixing system. Dissolved air is used for smaller bubbles. As in the case of BAF and the GEM system, large flocs entrained with air develop when high-molecular-weight flocculants are used. Multiple cylinders around the downcomer are used, similar to the modified jet-flotation cell. The air excess leaves through the centrifugal cylinders at the top, and the flocs float very fast within seconds after leaving the downcomer cylinder. A novel flocculation and helical mixing system has also been developed by the same group (Carissimi and Rubio, 2005).

### **Applications of GEM System in Wastewater Treatment (example of hybrid centrifugal –dissolved air flotation system)**

As mentioned previously, the GEM system is particularly efficient in the treatment of wastewater with high solids loading (higher than 10 000 ppm of TSS). The GEM system was tested in the treatment of such oily wastewater from fish processing plants, rendering plants, snack-food processing plants, and salad-dressing processing plants. Water with up to 70,000 ppm of TSS and 150,000 of CODs was treated, and the TSS was reduced below 100 ppm, the CODs below 15,000 ppm, and complete removal of the FOGs was achieved. The GEM system is currently being tested as a polishing tertiary treatment before membrane separation. In such applications, where very low concentrations of TSS and FOGs are present (less than 10 ppm), the system shows great promise. Further, the GEM system was successful in removing TSS and FOG from fish-processing plants that use sea water with very high conductivity (up to 50,000 micromhos/cm). Appropriate

proprietary chemistry had to be used to flocculate particles and FOGs at such high ionic strength, under which conditions polymeric flocculants are difficult to uncoil. Positively charged coagulants such as aluminum sulfate were used to overcharge negatively charged solids. Then ultrahigh-molecular-weight, medium charge anionic emulsion flocculants, such as A-4816 from Cytec Corporation (molecular weight 40,000,000 D, 30% charge), were added to achieve bridging flocculation. LCPP mixing might have helped in the polymeric flocculant uncoiling process. Further research will test such a hypothesis. Performance of the GEM system is documented in Table 2.

**Table 2 - Examples of pilot plant and full - scale operating installations of GEM flotation systems**

Type of Wastewater	TSS before	TSS after	COD before	COD after
Seafood processor	3,500 ppm	120 ppm	27,000 ppm	10,000 ppm
Seafood processor	28,000 ppm	150 ppm	62,000 ppm	12,000 ppm
Rendering plant	25,000 ppm	80 ppm	67,000 ppm	13,000 ppm
Food processing	1,500 ppm	35 ppm	12,000 ppm	3,000 ppm
Municipal	285 ppm	50 ppm	320 ppm	180 ppm
Juice processing	385 ppm	10 ppm	9,000 ppm	5,500 ppm
Salad dressing	120,000 ppm	50 ppm	150,000 ppm	12,000 ppm
Jeans washing	30 ppm	3 ppm	100 ppm	60 ppm
Laundry	5,500 ppm	5 ppm	24,000 ppm	3,500 ppm
Snack food plant	45,000 ppm	55 ppm	130,000 ppm	10,000 ppm

## REFERENCES

- Bratby, J.; Marais, G.V.R., (1977) Flotation. In Purchas D.B. (Ed.), *Solid/Liquid Separation Equipment Scale –Up*. Upland Press, pp. 155-168.
- Bratby, J; Ambrose W. (1995) Design and Control of Flotation Thickeners. *Water Sci. Technol.*, **31**, 24-261.
- Bratby, J.; Jones G.; Uhte, W. (2004) State-of –Practice of DAFT Technology – Is there Still a Place for it? *77<sup>th</sup> Annual Conference of the Water Environ Federation, WEFTEC, New Orleans, L CD-ROM Conference Proceedings*.
- Carissimi, E.; Rubio, J. (2005) The Flocc Generator Reactor-FGR: A New Basis for Flocculation and Solid-liquid separation. *Int. J. Miner. Process.*, **75**, 237-247.
- Clayton, R.; Jameson, G.J.; Manlapig, E.V. (1991) The Development and Application of Jameson Cell. *Mineral Engineering*, **4**, 925-933.
- Colic, M.; Morse, D.E.; Morse, W.O.; Matherly, T.G.; Carty, S.; Miller J.D. (2001) From Air-sparged Hydrocyclone to Bubble Accelerated Flotation: Mineral Industry Technology sets Stage for Development of New Wastewater Treatment Flotation. *Proceedings Engineering Foundation Conference, Froth Flotation/Dissolved Air Flotation: Bridging the Gap*, UEF Conferences, Tahoe City, California, in press.
- Da Rosa, J.; Rubio, J. (2005) The FF (flocculation-flotation) Process, in *Minerals Engineering* (web version available at [www.elsevier.com/locate/mineng](http://www.elsevier.com/locate/mineng)), in press.
- Desam, P.R.; Datta, A.; Morse, W.; Miller, J.D. (2001) A Computational Fluid Dynamics (CFD) Model for a Bubble Separation Tank Used in Wastewater Treatment, *Proceedings Engineering Foundation Conference, Froth Flotation/Dissolved Air Flotation: Bridging the Gap*, UEF Conferences, Tahoe City, California, in press.
- Fan, A.X.; Turro, N.J.; Somasundaran, P.; (2000) A Study of Dual Polymer Flocculation. *Colloids Surf. A*, **162**, 141-148.
- Feris, L.A.; De Leon, A.T.; Santander M.; Rubio, J. (2004) Advances in The Adsorptive Particulate Flotation Process, *Int. J. Miner. Process.*, **74**, 101-106.
- Jameson, G.J. (1999) Hydrophobicity and Flocc Density in Induced-air Flotation for Water Treatment. *Colloids Surf. A*, **151**, 269-281.
- Kiuri, H.J. (2001) Development of Dissolved Air Flotation Technology from the 1<sup>st</sup> Generation to the Newest 3<sup>rd</sup> one (very thick microbubbles) with High Flow-rates (DAF in turbulent flow conditions). *Water Science and Technology*, **8**, 1-8.
- Miller, J. D. (1981) Air-sparged Hydrocyclone and Method. *US Pat. 4,279,743*.
- Morse, D.E.; DeWitt, J.B.; Gnegy, B.; Hendrickson, E.D.; Jovine, R.; Matlick, A.; Matherly, T.G.; Morse, W.O.; Owen, J.J.; (2000) Fluid Conditioning System and Method. *US Pat. 6,106,711*.
- Morse, D.E.; Hendrickson E.D.; Jovine, R.; Morse, W.O.; Mandoza D.W.; (2001) Fluid Conditioning System. *US Pat. 6,171,488*.
- Morse, D.E.; Morse, W.O.; Matherly T.G.; Hendrickson E.D. (2001) System and method to improve flotation systems. *US Patent Application 20010032812*.
- Morse, D.E; Morse W.O; Matherly, T.G (2004a) System and method of gas energy management for particle flotation and separation. *US Patent Application 20040178152*.
- Morse, D.E.; Morse, W.O.; Matherly, T.G. (2004b) Adjustable Contaminated Liquid Mixing Apparatus. *US Patent Application 20040178153*.

- Owen, J.J.; Morse, D.E.; Morse, W.O.; Jovine, R. (1999) New Developments in Flotation Equipment for Water Treatment Systems, in *Advances in Flotation Technology*, B.K. Parekh and J.D. Miller, eds., SME, Littleton, Colorado, pp. 381-389.
- Ross, C.C.; Smith, B.M.; Valentine, G.E. (2000) Rethinking Dissolved Air Flotation (DAF) Design for Industrial Pretreatment. *2000 Water Environment Federation and Purdue University Industrial Wastes Technical Conference, St. Louis, Missouri*, CD-ROM Conference Proceedings.
- Ross, C.C.; Valentine, G.E.; Smith, B.M.; Pierce, J.P. (2003) Recent Advances and Applications of Dissolved Air Flotation for Industrial Pretreatment. *2003 Industrial Water/Wastewater Program, North Carolina AWWA/WEA Annual Conference, Greensboro, North Carolina*.
- Rubio, J; Souza, M.L., Smith, R.W. (2002) Overview of Flotation as a Wastewater Treatment Technique. *Minerals Eng.*, **15**, 139-155.
- Ta, C.T.; Beckley, J.; Eades, A. (2001) A Multiphase CFD Model of DAF Process. *Water Sci. Technol.* **43**, 153-157.