

## Case Study: Pretreatment of Challenging Pork Rinds Manufacturing Wastewater

<sup>1</sup>Miroslav Colic, Clean Water Technology, Inc.  
Wade Morse, Clean Water Technology, Inc.  
Ariel Lechter, Clean Water Technology, Inc.  
<sup>1</sup>Clean Water Technology, Inc.  
151 W135th Street  
Los Angeles, CA 90061

### ABSTRACT

**Problem:** Gaytan Foods facilities in City of Industry (Los Angeles, CA) manufacture pickled pork rinds, pickled pig feet and “cheese” puffs. The resulting wastewater is loaded with FOG’s, proteins and salts. Wastewater varies hourly and daily. Drastic changes in amount and type of contaminants occur (two orders of magnitude). During some hours wastewater is loaded with proteins, and as it cools down, highly viscous gel is produced. Protein degradation produces hydrogen sulfide (odor problem).

**Goals and Objectives:** Local municipality complained about amount of FOG in wastewater and formation of gel in pipes. Reduction of BOD was also suggested. Odor problems (hydrogen sulfide) also had to be dealt with. The goal was to design and build wastewater treatment plant that will reduce amount of FOG, TSS and BOD and prevent formation of gel and hydrogen sulfide.

**Solution:** Wastewater treatment plant was designed and installed to deal with those problems. Rotating drum screen was installed to remove large particles and objects. Large equalization tank collecting 24 hours of produced wastewater with intense mixing was installed to prevent gelation. Equalization also helped reduce the salinity of the stream (dilution with low salinity streams). Following equalization, flocculation – flotation system was used for primary treatment. Individual samples were very difficult to coagulate and flocculate. Large amounts of flocculants were needed to achieve the flocculation. This made the process too expensive. However, equalization solved these problems. Equalized stream was easy to flocculate. Hybrid centrifugal – dissolved air flotation system reduces TSS to less than 50 mg/l and FOG to less than 5 mg/l. Dissolved BOD’s are also removed, probably due to flocculation of some large protein molecules. Total BOD’s reductions average around 75%. Aeration of the equalization tank prevents formation of hydrogen sulfide. This significantly reduces odor problems. Since the installation of the system, gel formation in pipes never occurred, either. Flotation produces sludge with over 25% of solids that is reused (pet food manufacturing). Municipal wastewater treatment plant has no problem with treatment of dissolved BOD’s that remain in wastewater after the pretreatment. Fees and fines that Gaytan Foods faced in the past are significantly reduced or eliminated (fines). In the future, even more robust odor control will be attempted (deodorizing solutions).

**KEYWORDS:** flocculation – flotation, FOG, protein and BOD removal, odor control

## INTRODUCTION

Snack food manufacturing often produces wastewater with very high concentrations of fats oil and grease (FOG), suspended solids (TSS) and dissolved organics (measured as COD or BOD). Dissolved organic materials include proteins, carbohydrates, food coloring and additives etc. Manufacturing wastewater is mixed with cleaning in place (CIP) streams with high pH and detergents present. FOG's and TSS are often most objectionable contaminants due to coating of pipes and other surfaces and unpleasant odor issues. Dissolved proteins also contribute to the

**Figure 1 - Schematic Presentation of the Wastewater Treatment Plant at the Gaytan Foods**

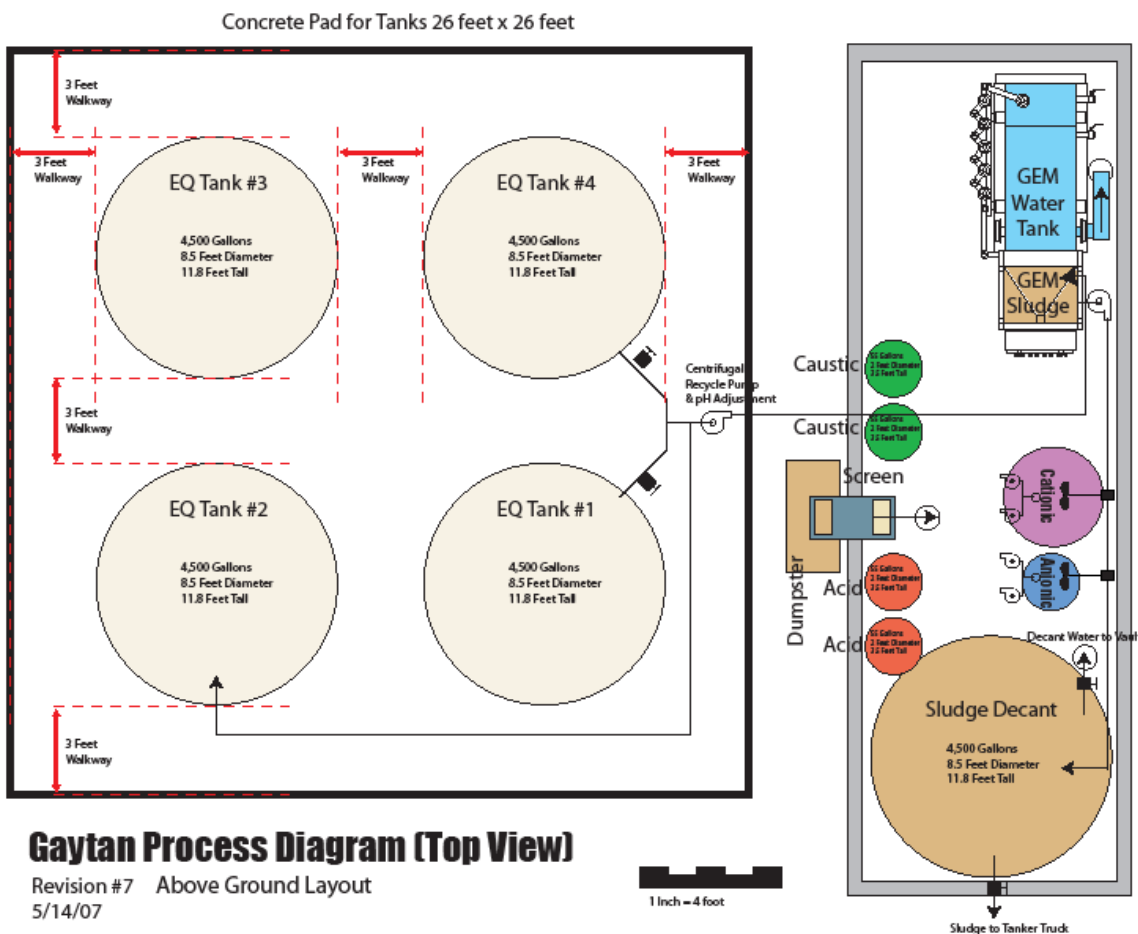

unpleasant odors (hydrogen sulfide). Pretreatment systems are often designed to remove maximum amount of TSS, FOG and macromolecules. Other dissolved contaminants can then be removed in the municipal treatment plants.

Food manufacturing streams vary hourly, daily and seasonally. Contaminant concentration is often order of magnitude higher than in the sewage wastewater. This presents significant challenges to the pretreatment systems. Solid/liquid separation systems that can handle large amount of solids and FOG's (up to 50,000 mg/l) and respond fast to changing wastewater are needed. Such systems have only recently become available.

In this manuscript we describe development and full scale installation of one such pretreatment system that was installed at Gaytan Foods facilities in City of Industry (Los Angeles County), California.

Gaytan Foods was started in 1935. In 2007 company moved to award winning 64,000 square foot facility in City of Industry. Company is now the largest producer of pickled pork rinds and pickled pork feet in the United States. Company also produces “cheese puffs.” Manufacturing process includes cooking at high temperature and pressure. This results in wastewater with high amount of high molecular weight proteins from skin and joints. Such proteins contain high amount of cystein, a sulfur rich amino acid. Crosslinked protein chains dissolved at high temperature in water produce a viscous gel on cooling. Formation of gel in pipes, tanks and elsewhere results in serious challenges for wastewater pretreatment system. Decomposition of cystein rich proteins also results in production of hydrogen sulfide under anaerobic conditions. In addition to that, pork skin and pig feet pickling also results in waste streams with very high amount of FOG’s (up to 30,000 mg/l). Neighbors and local municipality complained about formation of gel in pipes, FOG deposition and odor problems. The management decided in 2007 to install a pretreatment system that will address those issues. System will be described in this manuscript.

## **THE TREATMENT SYSTEM**

The wastewater treatment plant was designed and installed to deal with the above described issues. The schematic presentation of the system is illustrated in the Figure 1. Large equalization tanks collecting 24 hours of produced wastewater with intense mixing to dilute gel forming and high salinity pickling streams were installed. Intense mixing also keeps the streams aerobic, reducing the amount of hydrogen sulfide in the water and air. Self – cleaning rotating drum screen was installed to remove large particles and objects. After screening, the pH of waste stream was adjusted with sodium hydroxide or sulfuric acid. Following pH adjustment coagulation and flocculation – flotation was performed with the GEM System. Skimmed sludge was collected in the sludge hoper and decanted in the sludge drain tank

### **Coagulation and flocculation – flotation**

Laboratory jar tests were performed with samples of wastewater collected every hour during 24 hours period. Individual samples were very difficult to flocculate. Many samples required close to 1,000 mg/l of cationic flocculant to flocculate. Protein rich samples gelled on cooling and could not be jar tested at all. Such samples had to be jar tested at 40 degrees celcius. High temperature decreases the efficiency of the flocculant. Table 1 shows TSS and COD as well as amount of flocculants used for individual samples. Mixing all 24 hours samples together solved the above described problems. The composite was easy to coagulate and flocculate, did not gel, and consumed reasonable amount of coagulants and flocculants (140 mg/l of cationic coagulant, 30 mg/l of cationic flocculant, 10 mg/l of anionic flocculant). Best breaks were achieved at pH’s between 9 and 9.5. Removal rates for composite well mixed samples were excellent (99% TSS and FOG removal, 75% COD removal, 65% protein removal). On average, TSS are removed below 50 mg/l, and FOG below 5 mg/l.

**Table 1 - Results of 24 hours composite jar test. Individual samples parameters.**

Sample	Hour/day	pH	TSS/ppm before	TSS/ppm after	COD/ppm before	COD/ppm after	cat flocc ppm	an flocc ppm
1	7pm;2/5	12.3	1,330	15	8,000	2,200	50	10
2	8	12.3	13,000	12	20,000	3,300	80	10
3	9	12.2	1,000	22	4,800	1,340	110	10
4	10	12	350	18	2,800	560	30	10
5	11	11.7	360	13	1,930	210	40	10
6	4am;2/6	12.3	450	11	2,200	150	40	10
7	5	11.7	1,000	15	2,500	100	40	10
8	6	12.1	750	23	6,000	120	40	10
9	7	4.1	6,000	22	16,000	6,000	30	10
10	8	4.8	7,200	20	17,000	9,000	90	10
11	9	4.8	1,800	12	33,000	16,000	100	10
12	10	4.9	2,200	15	15,000	2,300	120	10
13	11	11	4,400	19	23,000	12,000	100	10
14	12	11.2	2,200	17	26,000	18,000	800	20
15	1pm;2/5	9.7	2,300	22	20,000	4,000	650	20
16	2	9.7	2,200	15	16,000	3,610	120	10
17	3	6.3	2,000	16	13,000	6,000	1200	30
18	4	6.2	3,500	19	23,000	6,000	40	10
19	5	6	1,800	25	11,000	7,000	40	10
20	6	6	4,000	13	12,000	1,460	1200	30
21	12pm;2/7	10.8	1,300	23	6,200	150	80	10
22	1am;2/7	11	1,100	22	3,450	120	60	10
23	2	11.3	2,300	17	9,000	120	30	10
24	3	12.2	1,110	19	6,000	150	60	10
25	4	11.7	1,300	22	1,700	55	30	10

In full scale installed system best flocs were produced at pH's between 9 and 9.5. Low molecular weight epiamine coagulant and high molecular weight cationic and anionic granular flocculants produced largest most stable flocs and easy to dewater sludge. Freshly skimmed sludge contained 14-18% solids. After 24 hours of drainage, sludge with up to 25% solids is produced. Detailed description of the GEM system that was a centerpiece of the solid – liquid separation process follows below.

### **The Hybrid Centrifugal – Dissolved Air Flotation System: Gas Energy Mixing Management (GEM)**

#### **Description and Principles of Operation**

In dissolved-air flotation, bubbles are formed by a reduction in pressure of water pre-saturated with air at pressures higher than atmospheric and up to 120 psi. The supersaturated water is

forced through needle valves or special orifices, and clouds of bubbles 20 to 100 microns in diameter are produced. Yet, to avoid clogging of such orifices with particles, only 20% of already cleaned water is pressurized and recycled to the wastewater stream. This results in a low-energy mixing of the main wastewater stream and the bubble stream. Treatment chemicals, coagulants and flocculants have to be added in mixing tanks upstream. Floc separation happens in this tank, which requires quiescent conditions and a large footprint.

**Figure 2 – Schematic Presentation of the LCPP/LSGM**

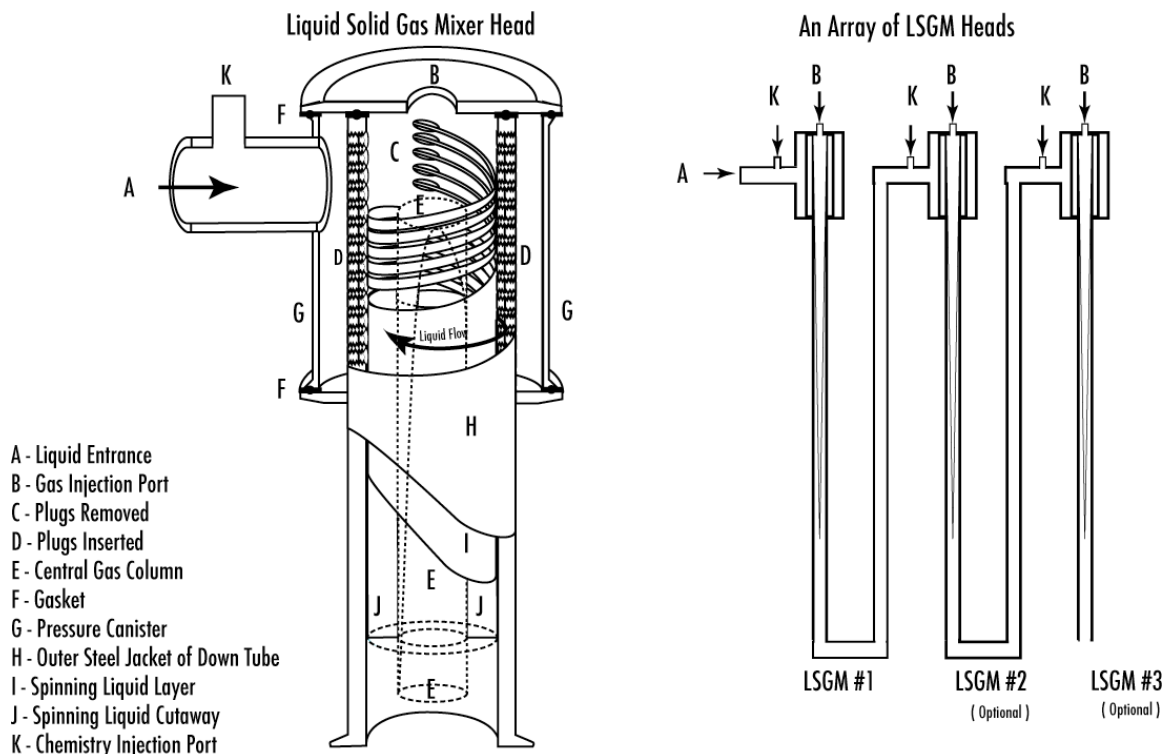

We proposed that a more efficient flotation system could be developed by combining high-energy centrifugal mixing of a liquid cyclone system (we termed it the liquid cyclone particle positioner, LCPP) with dissolved air as a source of flotation bubbles. Coagulants and flocculants can be delivered *in situ* directly into the flotation unit. The liquid – liquid hydrocyclone column was replaced with the LCPP for more efficient mixing of treatment chemicals, which occurs during bubble formation and nucleation. Such a procedure results in flocs, which are very porous and loaded with entrained and entrapped air.

As shown in Figure 2 the LCPP also acts as a liquid-solid-gas mixer (LSGM). Replacing the classical hydrocyclone head with the LCPP provides extremely energetic mixing by sequentially transporting liquid and entrained particles and gas bubbles throughout a centrifugally rotating liquid layer. Microturbulence in such vortices results in all particles and bubbles down to colloidal and molecular size acting as little mixers. Axial and radial forces inside the LCPP help

mix coagulants and flocculants with the particles. Uncoiling of polymer and better mixing of ultrahigh-molecular-weight polymers is achieved in the LCPP. Such efficient mixing is important for proper flocculation of suspended particles.

Further modification of LCPP heads, as opposed to hydrocyclone heads, introduced multiple holes with plugs inside the LSGM heads, as shown in Figure 3. By changing the number of plugs, we can modify the mixing energy and head pressure from very low to very high. In this way, we can mix low-molecular-weight coagulant at relatively high energy and high-molecular-weight flocculants at relatively medium and low mixing energy to promote final large floc formation.

Figure 4 presents a schematic of the GEM flotation system. It should be noted that for the sake of clarity only one LSGM head is presented. If more treatment chemicals are added, the LSGM head can be used to properly mix every additional chemical at its proper mixing energy (one mixing head per addition). Water and gas are introduced into the LSGM on top and pumped through the LCPP chamber. After rapid mixing (seconds), pressure is released with the cavitation plate. Nucleating bubbles and flocs are well mixed. As mentioned before, this results in the formation of large flocs full of entrained and entrapped air. Such flocs are already separated from water inside the LCPP nucleation chamber. As flocs enter the tank, they rise quickly to the top where they are skimmed and sent to solids dewatering devices.

As compared to other centrifugal flotation systems, the GEM system uses less energy, since there is no need for air blowers for air sparging. This also results in less noise. Controlled mixing energy produces stable flocs with much less carryover and higher solids loading. The footprint for this system is still only 10 to 20% of the classical DAF or clarifier devices. A blanket of small bubbles inside the tank acts as a "gas filter," filtering out clean water while preventing the transport of small pinpoint flocs into the clean water stream. Also, when wastewater with surfactants is treated, for some reason no foaming occurs inside the GEM system. Finally, it is possible to install sensors close to the nucleation chamber and observe any disturbance in flocculation performance almost instantaneously. This can be used to install turbidity-driven, chemical-additive dosage-control systems. Such systems can save significant amounts of money and produce a better quality of outgoing wastewater effluent. A detailed description of the GEM system can be found in Morse et al. (2008).

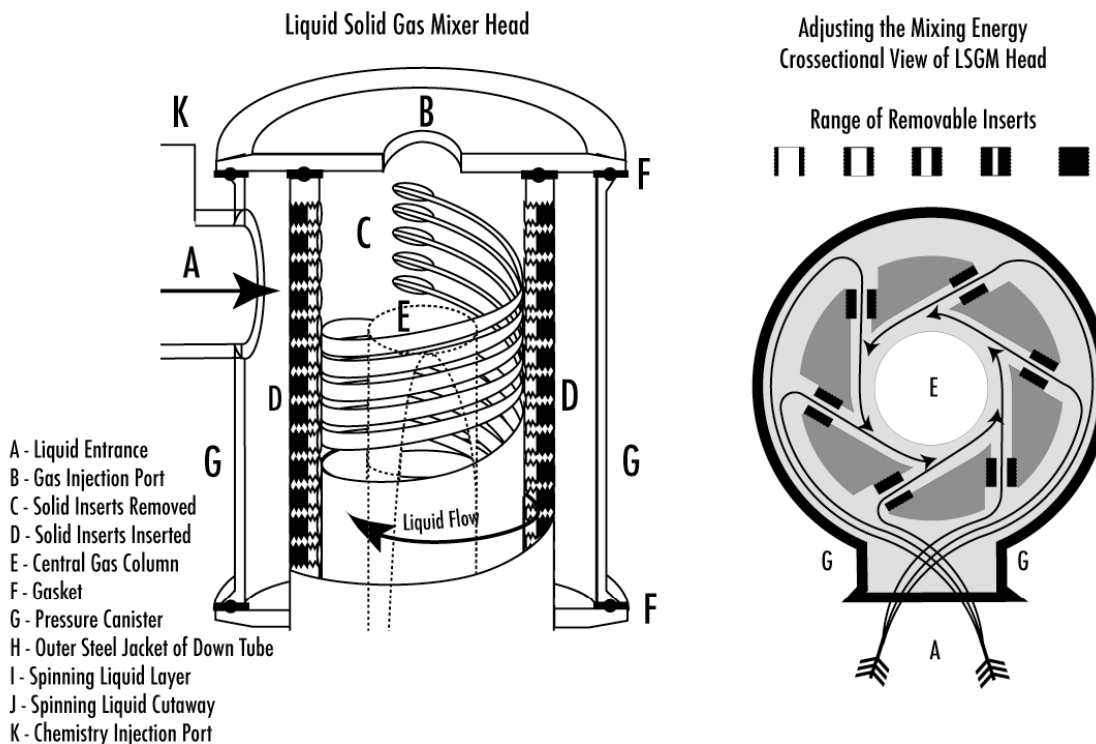

**Figure 3 – Schematic Presentation of the LSGM Heads**

**Figure 4 – Schematic Presentation of the Hybrid Centrifugal – Dissolved Air Flotation System**

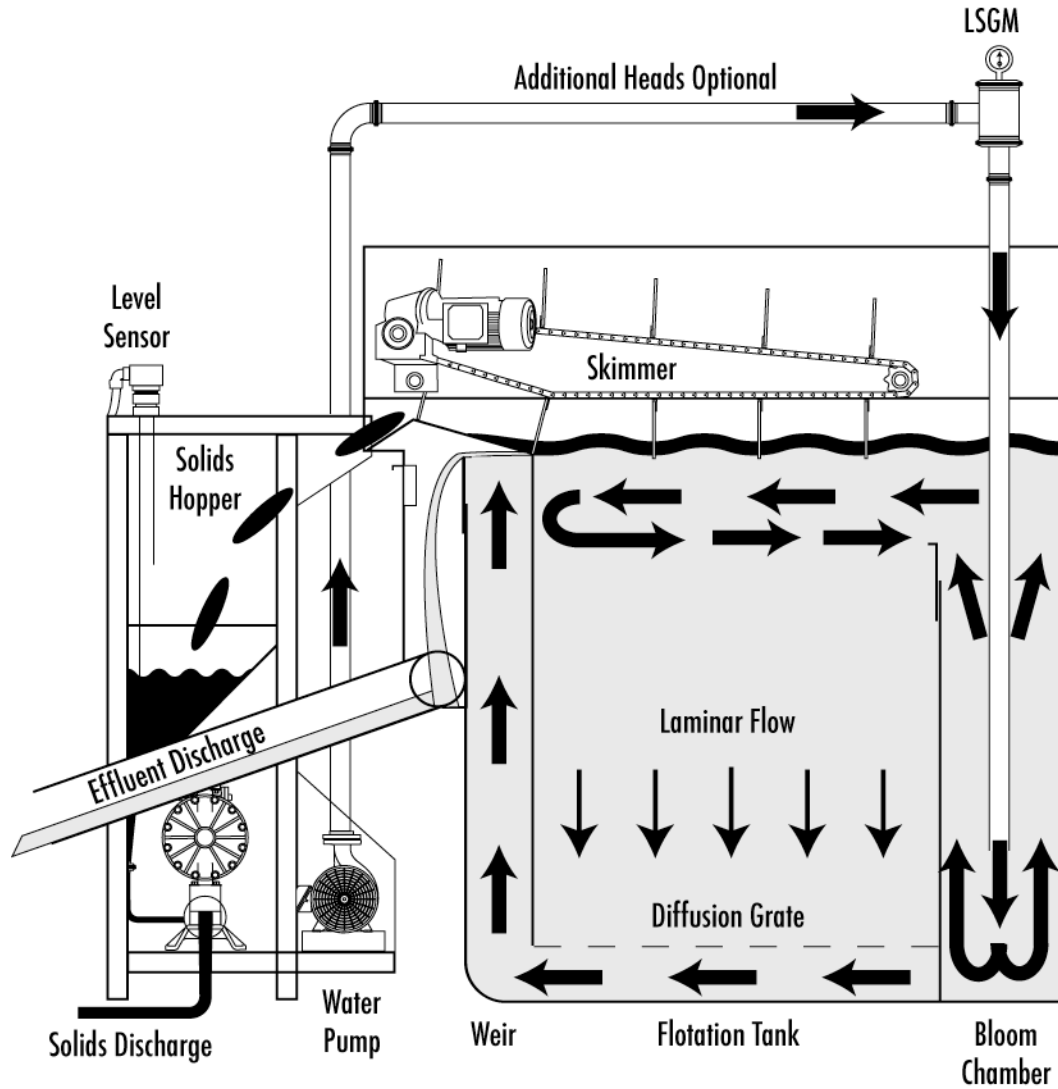

Figure 5 shows actual GEM system that was installed at the Gaytan Foods facilities.



**Figure 5 - Actual GEM system that was installed at the Gaytan Foods facilities**

## **CONCLUSIONS**

This manuscript describes industrial wastewater pretreatment plant installed at the Gaytan Foods facilities in City of Industry, CA. The installed system, consisting of large EQ tanks, screen, pH adjustment, coagulation, flocculation – flotation and sludge drain tanks is successful in removing objectionable contaminants such as FOG, TSS, odor forming substances and some BOD. The remaining BOD's are then removed at the municipal treatment plant.

## **REFERENCES**

Morse, D. E.; Morse, W. O., Matherly, Th. G. (2008) System and Method of Gas Energy Management for Particle Flotation and Separation, US Patent 7,374,689.